

Product Data

Multipoint Sampler and Doser — Type 1303

USES:

- m Air sampling in 6 locations, and delivery of the sample to Multi-gas Monitor Type 1302
- m Delivery of tracer-gas to 6 locations for air-exchange analyses with Multi-gas Monitor Type 1302

FEATURES:

- m Full remote-control from a personal computer over the IEEE488/IEC625-1 interface
- m 6 sample-input channels

- m 6 tracer-gas dosing channels
- m 6 temperature-transducer inputs
- m Automatic calculation of the amount of tracer-gas delivered to the dosing location
- m Discontinuous dosing facility
- m Self-calibrating dosing system
- m Self-testing

Introduction

Increasing numbers of legislative measures are aimed at improving air quality in workplace environments, for both employee comfort and safety. Such improvements in air quality require gas-monitoring equipment with the flexibility to provide sensitive and accurate monitoring under many different conditions, in different environments.

The Multipoint Sampler and Doser Type 1303 is remote-controlled from a personal computer over the IEEE488/IEC625-1 interface, and is used in conjunction with Multi-gas Monitor Type 1302 to provide a monitoring system which fulfils the above requirements of flexibility, sensitivity and accuracy.

The 1303 greatly increases the area-monitoring capabilities of the 1302 by drawing air-samples through tubing from up to 6 different sampling points – each being up to 50m distant – and delivering the samples to the 1302.

Comprehensive air-exchange analyses and ventilation-efficiency checks are easily performed using the dosing facilities of the 1303. Tracer-gas is delivered through tubing to 'label' the air in up to 6 different locations, each being up to 50m away; the amount of tracer-gas delivered is automatically calculated by the 1303. The 'labelled' air is then sampled again using the sampler system of the 1303, and delivered to the 1302 for analysis.



Up to 6 temperature transducers, connected to the 1303, can be positioned at the sampling/dosing points to give fuller information about the environment at that point.

The 1303's self-calibrating and self-checking routines allow easy checks of the

unit's operation, and ensure reliable functioning.

Description and Functions

The sampler system

The pneumatic system of the 1303 is shown schematically in Fig.1. The sampler system has 6 inlet channels, each with a solenoid valve. Each inlet channel has a tube-mounting stub on the front-plate of the 1303; 6 tubes of up to 50m length connect each channel to the respective sampling point. The 6 inlet channels converge into one; a three-way valve can then direct the gas sample to the 1302 for analysis, or through the pump to the waste-air outlet on the 1303's back-plate. A pressure transducer checks the efficiency of the sampling pump and allows checks for blocked airways.

Using the 1303's sampler system does not slow the 1302's monitoring capability: transporting a gas-sample from a sampling point 50m distant takes approximately 25s – less time than the 1302 takes to complete a measurement cycle. An air-filter is attached to the end of each sampling tube to keep the samples free of particles.

The doser system

The doser system has 6 outlet channels, each with a solenoid valve. Each channel has a nozzle which reduces the internal diameter of the channel. The nozzles ensure that the rate of flow of tracer-gas to the dosing points is dependent only upon the tracer-gas supply pressure and temperature, and is unaffected by the pressure in the dosing tubes or at the dosing point itself.

Three different nozzle sizes are used: four medium, one large, and one small. Each size gives a different volume flow rate so that the amount of tracer-gas delivered to a particular dosing point can be matched to the requirement at that point by using the outlet channel which has the appropriate nozzle.

Each of the 6 dosing outlet channels has a tube-mounting stub on the front-plate of the 1303. 6 tubes of up to 50m length connect each stub to the respective dosing point.

2 separate inlet channels mounted on the backplate of the 1303 serve the dosing channels: the tracer-gas inlet, and the carrier-air inlet.

The tracer-gas inlet channel is pressurized by the tracer-gas supply cylinder, which is connected to the inlet on the 1303's backplate by tubing. A pressure and a temperature transducer give information on the tracer-gas supply; a fine filter ensures that the dosing channels are particle-free. The main valve on the tracer-gas inlet channel is used to enclose a volume of tracer-gas between itself and the dosing

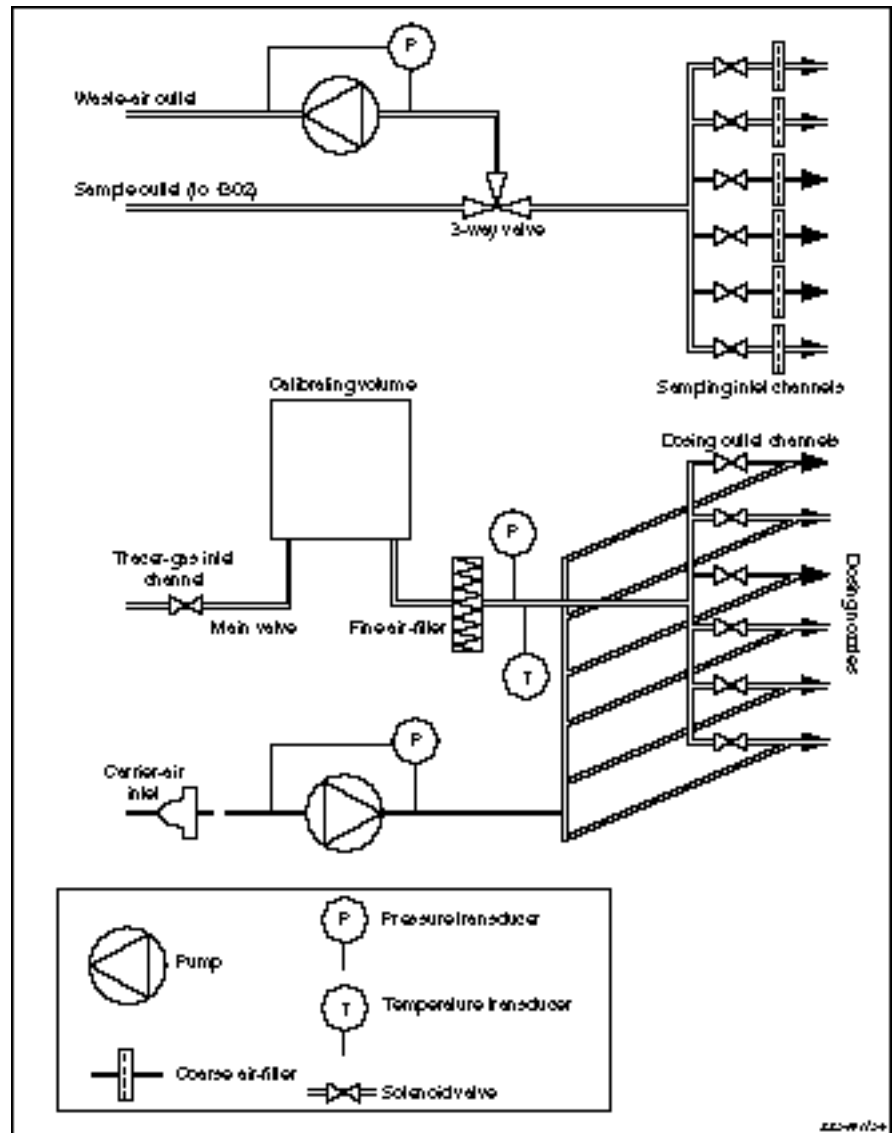

Fig.1 A schematic diagram of the 1303's pneumatic system: the sampler system is depicted at the top, the doser system at the bottom. The use of non-reactive materials throughout minimizes gas adsorption in the internal air-channels

valves. This volume is used when calibrating the doser system.

The carrier-air inlet pumps extra air to the dosing outlets to speed delivery of the tracer-gas to the dosing point. This inlet has a coarse air-filter, a pump, and a pressure transducer for checking the efficiency of the pump. Delivering a dose of tracer-gas to a dosing point 50 m distant takes 1 minute.

The dosing system can deliver a continuous dose, that is, an uninterrupted flow of tracer-gas over a period of time; or a discontinuous dose, in which the amount of tracer-gas delivered is reduced by interrupting the flow at regular intervals during the dosing period.

The doser system is set up for use by specifying a dosing time-out such that the 1303 will stop any current dosing procedure after a given time has elapsed without

instructions from the controlling computer. This value is specified from the controlling computer.

Calibrating the doser system

The 1303 can calibrate each dosing-nozzle automatically, so that the amount of tracer-gas delivered during a dosing procedure can be accurately determined by the 1303. A volume of tracer-gas is enclosed between the main valve and the dosing valves; this volume is then released through the nozzle to be calibrated. As the internal volume of the airways are known, the *effective outflow area* for each nozzle is calculated from the rate of pressure-decrease measured in the dosing airway. The amount of tracer-gas delivered can then be calculated from the effective outflow area, the tracer-gas supply pressure and temperature, and the dosing time-period.

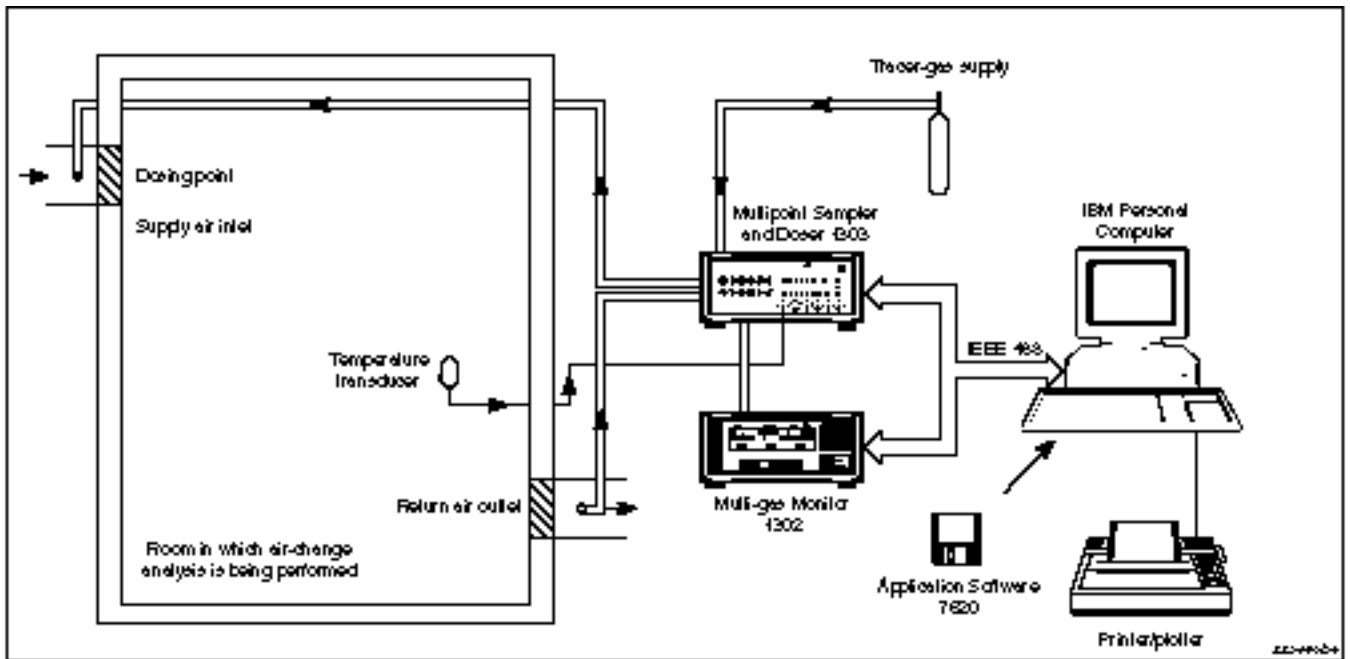

Fig.2 A typical air-change analysis system, shown with an application example. In this case, the aim of the analysis is to determine the size of the air-change in the mechanically ventilated room. The diagram shows only one dosing and sampling point, for clarity. Up to 6 similar analyses can be performed simultaneously using one 1303. Application Software Type 7620 gives control of all the functions of the system

Temperature measurement

To complete the information about the air environment at the sampling/dosing points, the 1303 is equipped with 6 temperature-transducer inputs, suitable for use with Air Temperature Transducer MM0034 and Operative Temperature Transducer MM0060. Each transducer can be positioned up to 50m away from the 1303. The measurement range of both transducers is from -20 to $+50^{\circ}\text{C}$, with an accuracy of $\pm 0.5^{\circ}\text{C}$.

Reliability

Reliability is ensured by automatic self-tests of both hardware and software. A check of the pneumatic system can be performed on request by the controlling computer. The 1303's operating status can be read-out at any time: if an error exists, the type of error is given to help repair.

Control of the 1303

The 1303 is fully remote-controlled from a personal computer over the IEEE/IEC interface. Control via the 1302 is also possible: the controlling computer communicates with the 1302 over the RS232C interface; the message is then transferred to the 1303 via the IEEE/IEC interface.

Commands and information requests are sent over the interface in clear language to the 1303 to control the sampler system; to

set-up, calibrate, and control the dosing system; and to read-out data and command the performance of self-tests.

System Use

The 1303 combines with the 1302 and a controlling computer to provide a system which offers wide-ranging monitoring capabilities. The 1303 makes it possible to perform multi-point air-exchange analyses and multi-point monitoring tasks in many different situations and environments, without changing the system components.

An example air-exchange analysis system is shown in Fig.2. In such a system, the doser/sampler systems of the 1303 are used as follows. The doser system marks the supply-air of the room with a known amount of tracer-gas. The sampler system then takes a sample of the return-air from the room, and delivers the sample to the 1302 for analysis. While the 1302 performs one analysis, the 1303 takes the next sample for analysis from the room. As the amount of tracer-gas delivered to the room is known, and the remaining concentration of tracer-gas in the samples is determined by the 1302, the ventilation-system performance can be calculated.

Brüel & Kjær Innova's Application Software Type 7620 is available to give full coordination and control of all the dosing/sampling and monitoring functions of such

systems. The 7620 controls one Type 1302 and up to two 1303 units.

A similar system set-up can be used for multi-point, multi-gas monitoring, using only the 1303's sampler system. This system can be remotely-controlled using Brüel & Kjær Innova Application Software Type 7300. The software coordinates the functions of the monitor and up to two multiplexers, which, via tubing, can perform gas-monitoring tasks in up to 12 different locations

Both the Type 7620 and Type 7300 display data in easy to read windows and run on IBM AT or PS/2 (model 50 or above) computers.

Specifications 1303

Warning! The 1303 must not be placed in areas with flammable gases/vapours in explosive concentrations, or be used for tasks in which explosive concentrations of these gases/vapours are monitored. Also note that certain aggressive gases could damage the internal airways of the 1303. Ask your local Brüel & Kjær Innova representative for further information.

The materials used in the construction of the 1303 ensure minimum adsorption of gases onto the internal components. The use of PTFE (polytetrafluoroethylene) tubing for connection to the sampling points, and nylon tubing for connection to the dosing points minimizes adsorption of gases within the tubing.

SAMPLING SYSTEM:

The following pressure and volume-flow data assumes the use of tubing of length 50m and internal diameter 3mm

Pump Performance:

Working pump suction: 20kPa
 Volume flow rate: 15ml/s
 Sample transport speed: 2m/s
 Three-way valve routes samples either to waste-air outlet or to the connected 1302
 Minimum pressure, blocked airways: 40kPa
 Maximum leakage into system: 10 µl/s at 30kPa suction and 10ml/s volume flow

DOSING SYSTEM:

The following pressure and volume-flow data assumes the use of Sulphur Hexafluoride (SF₆) as tracer-gas, and Nylon tubing of length 50m and internal diameter 3mm

Pump Performance:

Minimum working pump-pressure: 10kPa
 Volume flow rate of supplementary air per dosing channel: 4ml/s

Tracer-gas Supply:

From pressurized cylinder.
 Maximum supply pressure: 450kPa absolute
 Minimum supply pressure: 300kPa absolute
 Volume flow rate of tracer-gas at supply pressure of 300kPa absolute:
 Approximately 0.5ml/s (small nozzle)
 Approximately 3.0ml/s (standard nozzle)
 Approximately 15.0ml/s (large nozzle)
 Maximum time taken to deliver a dose of tracer-gas over a 50m distance through standard tubing: 1 minute

Pressure Transducer (Tracer-gas Supply):

Measurement range: 0 – 500kPa

Temperature Transducer:

Measurement range: +5 to +70 °C

Internal Volume of Doser System: 70ml

Accuracy of Dosage Calculation: ±2%

Maximum Leakage from Doser System:

0.4µls⁻¹ at 400kPa supply pressure absolute

TEMPERATURE TRANSDUCER INPUTS:

Compatible with Air Temperature Transducer MM0034

MM0034 measurement range: -20 to +50 °C

Accuracy: ±0.5°C between -20 and +50 °C

±0.2°C between +5 and +40 °C

SET-UP PARAMETERS:

Three set-up parameters are used.

Dosing Time-out: specifies the maximum time for which the 1303 will supply a dose of tracer-gas without further instructions from the controlling computer. Range of values: 1 – 3600s; default value: 60s

Characteristic Gas Constant: the ratio, R/M , of the universal gas constant ($R=8314\text{Jmol}^{-1}\text{K}^{-1}$) and the gram molecular weight (M , g mol^{-1}) of the tracer-gas used.

Range of values: from 1 — 10000

Calibration Data: the effective outflow area of a specified dosing nozzle: measured in $\text{m}^2 \cdot 10^{-9}$

IEEE INTERFACE:

Conforms with IEEE Std. 488-1978, compatible with IEC 625-1. All functions of the 1303 are

COMPLIANCE WITH STANDARDS:

controlled over the interface; output of status information and dosing data

Functions Implemented:

- Source Handshake – SH1
- Acceptor Handshake – AH1
- Talker – T5
- Listener – L3
- Service Request – SR1
- Parallel Poll – PP1
- Device Clear – DC1

POWER SUPPLY:

100 – 127V; 200 – 240V AC 50 – 400Hz, 70VA
 Complies with Safety Class I of IEC Publication 536

DIMENSIONS:

Height: 175mm (6.9ins)

Width: 395mm (15.6ins)

Depth: 300mm (11.8ins)

Weight: 9kg (19.8lb)

	CE-mark indicates compliance with: EMC Directive and Low Voltage Directive.
Safety	EN 61010-1 (1993) & IEC1010-1 (1990): Safety requirements for electrical equipment for measurement, control and laboratory use.
EMC Emission	EN 50081-1 (1992): Generic emission standard. Part 1: Residential, commercial and light industry. EN 50081-2 (1993): Generic emission standard. Part 2: Industrial environment. CISPR 22 (1993): Limits and methods of radio disturbance characteristics of information technology equipment. Class B Limits. FCC Class B limits.
EMC Immunity	EN 50082-1 (1992): Generic immunity standard. Part 1: Residential, commercial and light industry. EN 50082-2 (1995): Generic immunity standard. Part 2: Industrial environment. Note: The above is guaranteed using accessories listed in this Product Data sheet only.
Temperature	IEC 68-2-1 & IEC68-2-2: Environmental Testing. Cold and Dry Heat. Operating Temperature: +5 °C to +40°C (41°F to 104°F) Storage Temperature: -25 °C to +70°C (-13°F to +158°F)
Humidity	IEC 68-2-3: 90% RH (non-condensing at 40 °C)
Enclosure	IEC 529: IP 20
Mechanical	IEC 68-2-6: Vibration: 0.3 mm, 20 m/s ² , 10-500 Hz IEC 68-2-27: Shock: 1000 m/s ² IEC 68-2-29: Bump: 3000 bumps at 250m/s ²

Ordering Information

Type 1303	Multipoint Sampler and Doser	Instruction Manual	MM0060: Operative Temperature Transducer
Includes the following accessories:			AO0265: IEEE488 Interface cable
7×DS2306:	External fine air-filters for sampling tubes	Optional Accessories	WL0845/0.4: IEEE488 Interface cable for connecting 1303 to 1302 (0.4m)
7×UD5041:	Fitting for air-filters		AF0614: PTFE tubing
3×YM0652:	Knurled nuts to secure tubing to nozzles	Type 1302: Multi-gas Monitor	AF0007: Nylon tubing
AT2247:	Nylon tubing for connection of tracer-gas supply (1.5m)	Type 7300: Application Software (for monitoring only)	WQ 0916: Water-trap Filter
DH0541:	Carrying strap	Type7620: Application Software (for dosing and monitoring)	WQ 1106: Filter cartridges (3) for use with WQ0916
Mains cable		MM0034: Air Temperature Transducer	

Brüel & Kjær Innova reserves the right to change specifications and accessories without notice



Brüel & Kjær
INNOVA A/S

Skodsborgvej 307
DK-2850 Nærum, Denmark

Tel.: (+45) 42 80 05 00
Fax: (+45) 45 80 68 84

International Agents

Australia Tel.: 02 450 2066 Fax: 02 450 2379
Austria Tel.: 1 406 4310 Fax: 1 405 8171/
Belgium Tel.: 016 449 225 Fax: 016 449 230
Brazil Tel.: 011 246 8166 Fax: 011 246 7400
Canada Tel.: 905 564 4700 Fax: 905 564 6776
CIS Tel.: 7 95 212-3834 Fax: 7 95 212-3838

Germany Tel.: 04193-92739 Fax: 04193-93421
Holland Tel.: (0) 30 6039994 Fax: (0) 30 6041894
Hong Kong Tel.: 548 7486 Fax: 858 1168
Italy Tel.: 049 89 30055 Fax: 049 72 5659
Japan Tel.: (03) 3779-8672 Fax: (03) 3779-8690
Poland Tel.: 0-22 40 93 92 Fax: 0-22 40 82 21

Slovak Rep. Tel.: 07 3789520 Fax: 07 376179
Spain Tel.: 91 386 1000 Fax: 91 407 7456
Switzerland Tel.: 055 31 9401 Fax: 055 31 9419
UK Tel.: 0181 954 2366 Fax: 0181 954 5584
USA Tel.: 1-800 332 2040 Fax: 818-770 808